



DESCRIPTION

**094IHV**

Insulating cases for PICV 94F and 95F series.

Sandwich structure:

- external layer made by high density insulating material to make it hard;
- internal layer made by low density insulating material with high insulation performance.

Made by 2 shells with Velcro®.

MATERIALS

Body (external layer)

Polyethylene cross linked foam, density 80 kg/m<sup>3</sup>

Body (internal layer)

Polyethylene cross linked foam, density 29 kg/m<sup>3</sup>

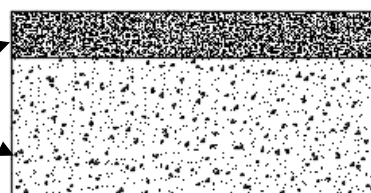

TECHNICALS CHARACTERISTICS OF INSULATION

	Standard	Insulation case	
Density [Kg/m <sup>3</sup> ]	ISO 845	29	80
Compression stress (50% deflection) [kPa]	ISO 3386/1	88	260
Tensile strength longitudinal [Mpa]	ISO 1798	0.18	0.8
Extension longitudinal stretch [%]	ISO 1798	120 (at break)	170 (at break)
Residual distortion 22 h at 23°C [%] <small>Deflection of 25% 24h after release</small>	ISO 1856	13	1.5
Operating temperature range [°C]	-	-60/+90	-60/+90
Thermal conductivity [W/mK]	EN 12667	0.040	0.049
Fire resistance rating		1 – UNI9177	B2 – DIN4102
UL fire rating	UL94	HF-1	HF-2

Total shell thickness conform to RITE/2007 (E) requirements

DIMENSIONS

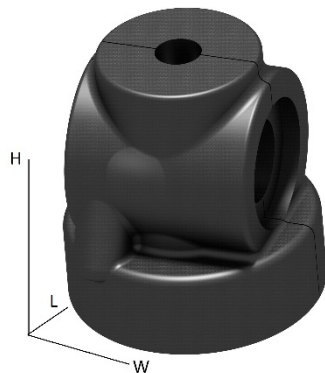

Dimensions in mm

Valve size	L	W	H	Thickness	Weight [g]
94FH / 95FH 2" 20.000 l/h	320	320	375	35	550
94FL 2 1/2" 20.000 l/h	340	340	380	35	540
94FH / 95FH 2 1/2" 30.000 l/h	340	340	380	35	540
94FL / 95FL 3" 30.000 l/h	355	355	390	36	550
94FL / 95FL 4" 55.000 l/h	475	475	485	43	1050
94FL 5" 90.000 l/h	478	478	535	43	1200
94FH 5" 120.000 l/h	478	478	535	43	1200
94FL / 95FL 6" 90.000 l/h	480	480	530	43	1200
94FH / 95FH 6" 150.000 l/h	480	480	630	-	-
94FL 8" 200.000 l/h	485	545	730	-	-
94FH 8" 300.000 l/h	485	545	730	-	-
94FL 10" 300.000 l/h	605	730	815	-	-
94FH 10" 500.000 l/h	605	730	815	-	-